

OIL/WATER SEPARATOR - 4'-0" DIA. (H-20) OWS-4DIA-H-20

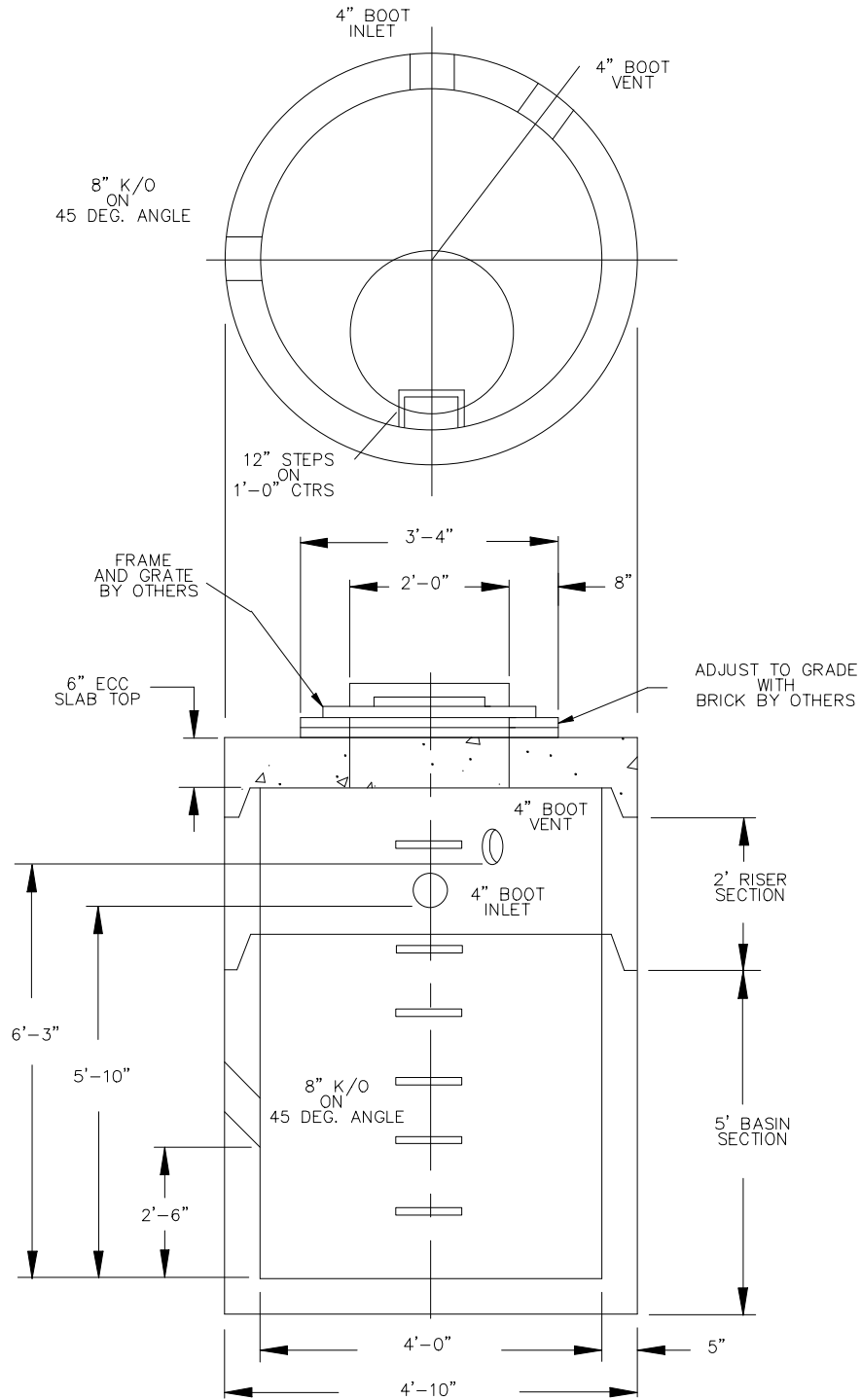

SPECIFICATIONS

- Concrete Minimum Strength: 5,000 P.S.I @ 28 days
- Steel Reinforcement: AS-615-68, Grade 60
- Design Loading: AASHTO - H-20 Meets ASTM Spec. C1227